

Brazing Paste Dispensing Gun

PST 1501

PASTA SURME TABANCASI

Paste Applicator Gun

The Model PST-1501 Applicator Gun is compatible with PASTÖR Controller, and is machine integration capable. Dispense premeasured deposits or stripes of OKBRAZE Paste Alloy. Exclusive positive displacement principle ensures repeat accuracy for daily, trouble-free production.

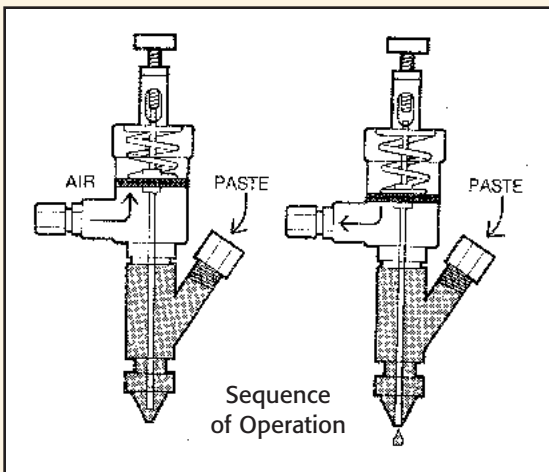
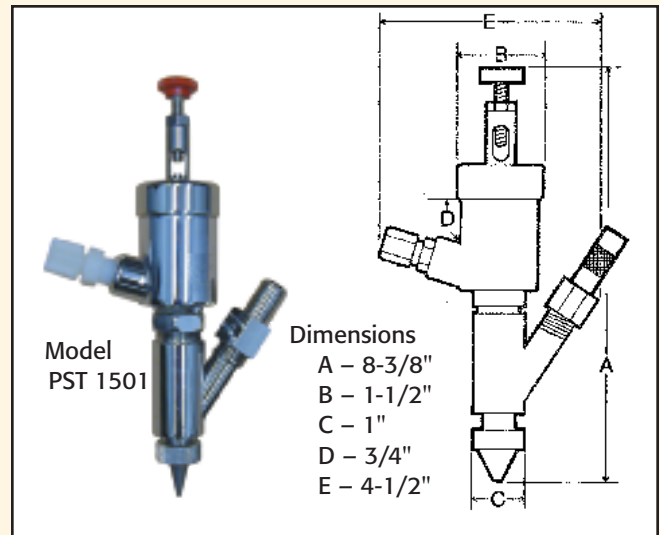

Fig. 1 – Compressed air from controller is introduced to upper gun body, forcing circular piston and attached piston rod upward against coil spring. Pressurized paste alloy (from reservoir) fills vacant space between piston rod tip and nozzle orifice.

Fig. 2 – As timer de-energizes, compressed air is exhausted, and coil spring returns piston and rod to closed position. Piston rod tip displaces paste alloy through nozzle orifice and seals opening until next cycle. Precise deposit size is obtained by adjusting control panel timer, paste pressure, and length of piston rod stroke.

NOTE: Other gun styles available for specialized applications.



OKBRAZE JOINING & AUTOMATION

www.sertlehimleme.com